

THE INFORMATION CONTAINED IN THIS DRAWING IS THE SOLE PROPERTY OF RAY-VIN, INC. ANY REPRODUCTION IN PART OR WHOLE WITHOUT THE WRITTEN PERMISSION OF RAY-VIN, INC. IS PROHIBITED. CONTACT:
 RAY-VIN, INC., 1844 MT CELLO RD
 MARIANNA, FL 32448-5365
 1-850-482-7562 email: rvb@ray-vin.com
 www.ray-vin.com

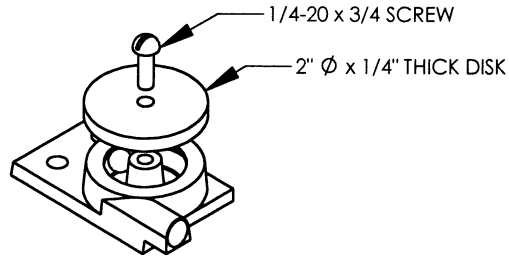

NOTE:
 DRILL AND TAP 1/8 NPT FOR AIR INLET THEN
 TILT CASTING AT AN ANGLE (ABOUT 12°)
 AND DRILL THE 1/16 HOLE THRU.

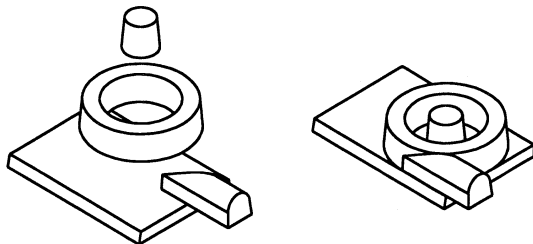
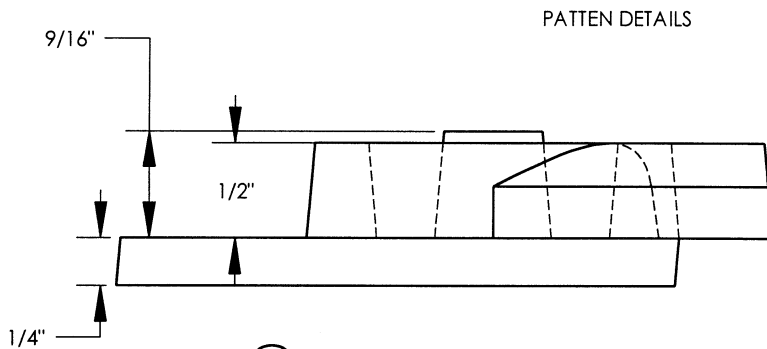
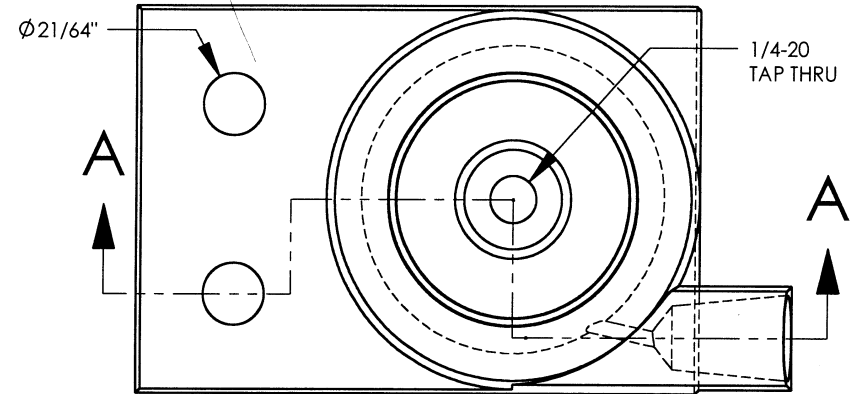
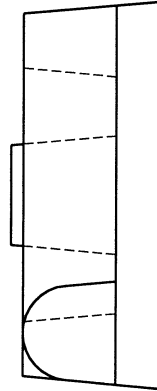
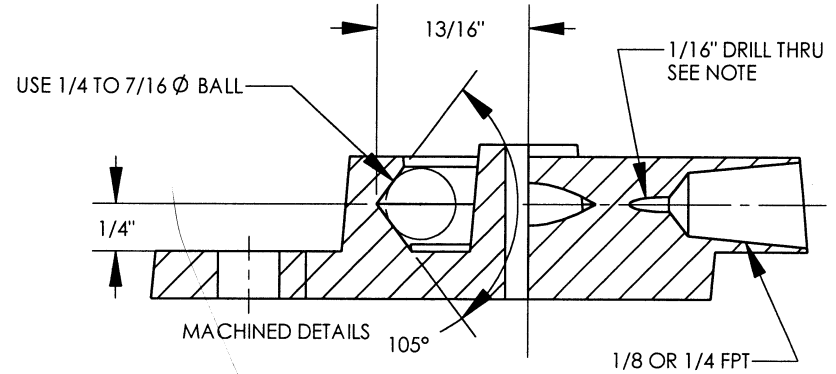
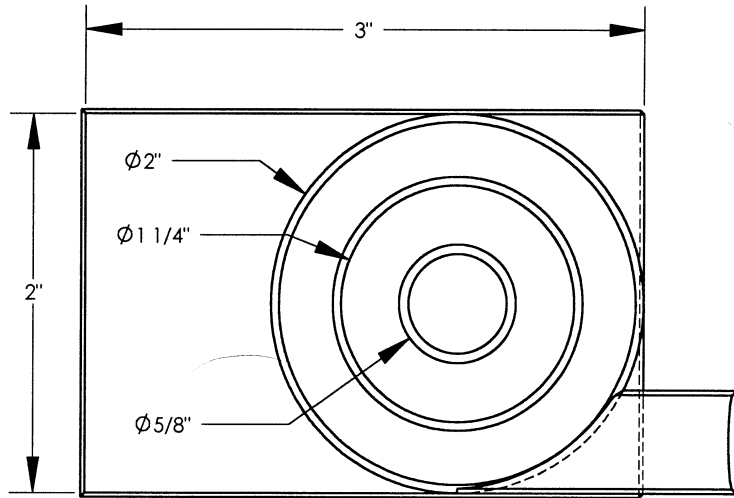

ITEM NO.	PART OR IDENTIFYING NO.	NOMENCLATURE OR DESCRIPTION	MATERIAL SPECIFICATION	QTY REQD
PARTS LIST				
UNLESS OTHERWISE SPECIFIED DIMENSIONS ARE IN INCHES TOLERANCES ARE: FRACTIONS DECIMALS ANGLES + .XX+ .XX + 1 .XXX+.XXX		CAD GENERATED DRAWING. DO NOT MANUALLY UPDATE	RAY-VIN, INC. PNEUMATIC VIBRATOR	
MATERIAL 6061 T6		APPROVALS DATE DRAWN RVB 4/23/02		
FINISH --		CHECKED RESP ENG		
NEXT ASSY USED ON		MFG ENG		
APPLICATION		DO NOT SCALE DRAWING	QUAL ENG	REV.
SIZE A		DWG. NO.	Mold Vibrator	
SCALE		CAD FILE:	SHEET OF	

8 7 6 5 4 3 2 1