

THE INFORMATION CONTAINED IN THIS DRAWING IS THE SOLE PROPERTY OF RAY-VIN, INC. ANY REPRODUCTION IN PART OR WHOLE WITHOUT THE WRITTEN PERMISSION OF RAY-VIN, INC. IS PROHIBITED. CONTACT:
 RAY-VIN, INC., 1844 MT CELLO RD
 MARIANNA, FL 32448-5365
 1-850-482-7562 email: rvb@ray-vin.com
 www.ray-vin.com

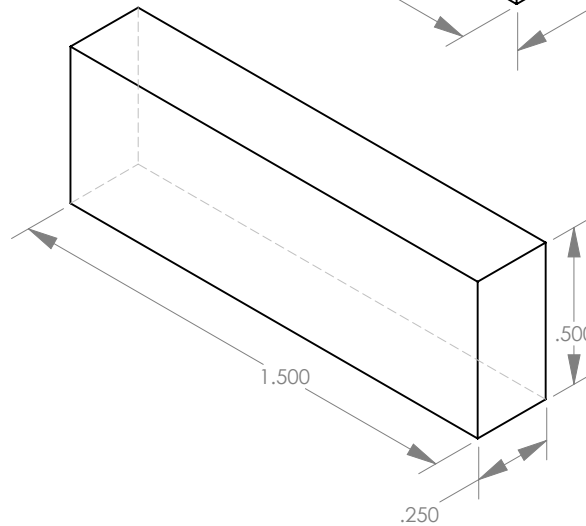

ITEM NO.	PART OR IDENTIFYING NO.	NOMENCLATURE OR DESCRIPTION	MATERIAL SPECIFICATION	QTY REQD
PARTS LIST				
UNLESS OTHERWISE SPECIFIED DIMENSIONS ARE IN INCHES		CAD GENERATED DRAWING, DO NOT MANUALLY UPDATE		RAY-VIN, INC.
TOLERANCES ARE:		APPROVALS	DATE	
FRACTIONS .XX+ .XX + 1		DRAWN RVB	Nov 2009	M1 CLIP LOADER PUSHER PARTS
DECIMALS .XXX+.XXX		CHECKED		
ANGLES		RESP ENG		
MATERIAL 1018 CRS		MFG ENG		SIZE A
FINISH PARKERIZE		QUAL ENG		DWG. NO. SCL-15
NEXT ASSY	USED ON	DO NOT SCALE DRAWING		SCALE
APPLICATION		SCALE	CAD FILE:	SHEET OF

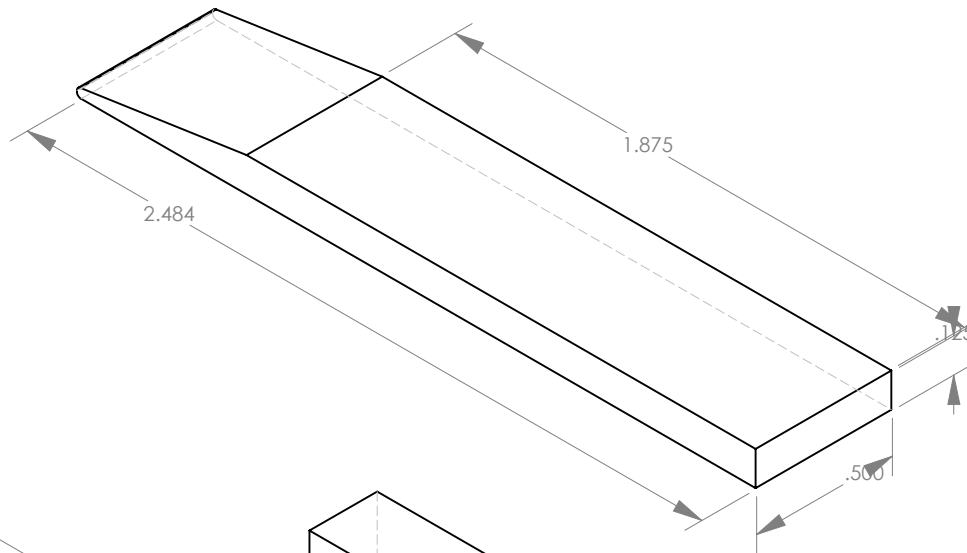
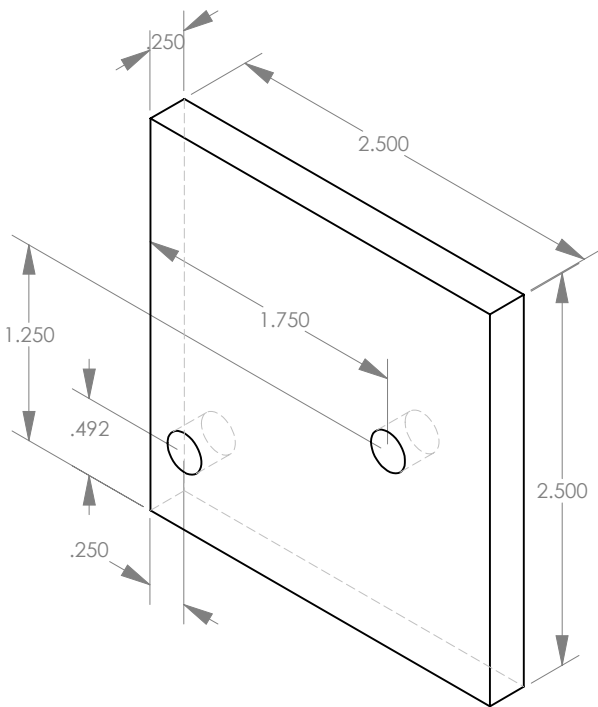